

Винт Vira самопробивен за метал 4.2x32 мм, фрезенкова глава, PH, A2, DIN 7504P



DIN 7504 M (N) sim. UNI 8118 N EN ISO 15481

Vite perforante a testa cilindrica bombata con impronta croce (Phillips H) e filett. autofilettante

Cross recessed (Phillips H) pan head drilling screw with tapping screw thread

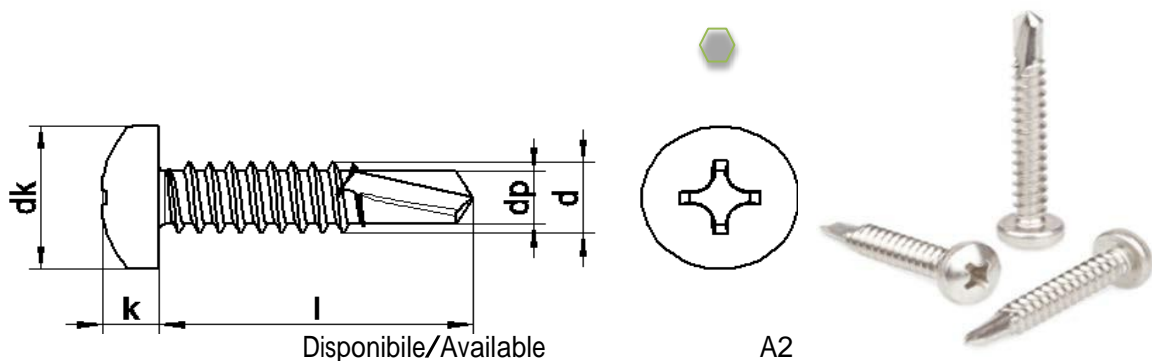

Sp. Lamiera* Thk. sheets	0,7 + 0,7 = 1,4	1 + 1 = 2	1 + 1 = 2	1 + 1 = 2	1,5 + 1,5 = 3	2 + 3 = 5	2 + 3 = 5	
dp	2,3	2,8	3,1	3,6	4,1	4,8	5,8	
dk	max.	5,60	7,00	7,50	8,00	9,50	11,00	12,00
	min.	5,30	6,64	7,14	7,64	9,14	10,57	11,57
k	max.	2,40	2,60	2,80	3,10	3,70	4,00	4,60
	min.	2,15	2,35	2,55	2,80	3,40	3,70	4,30
[phillips]	1	2			3			
l/d	ST2,9	ST3,5	(ST3,9)	ST4,2	ST4,8	ST5,5	ST6,3	
9,5	2,9x9,5	3,5x9,5	3,9x9,5					
13	2,9x13	3,5x13	3,9x13	4,2x13	4,8x13			
16	2,9x16	3,5x16	3,9x16	4,2x16	4,8x16	5,5x16		
19	2,9x19	3,5x19	3,9x19	4,2x19	4,8x19	5,5x19	6,3x19	
22		3,5x22	3,9x22	4,2x22	4,8x22	5,5x22	6,3x22	
25		3,5x25	3,9x25	4,2x25	4,8x25	5,5x25	6,3x25	
32			3,9x32	4,2x32	4,8x32	5,5x32	6,3x32	
38			3,9x38	4,2x38	4,8x38	5,5x38	6,3x38	
45					4,8x45	5,5x45	6,3x45	
50					4,8x50	5,5x50	6,3x50	
60					4,8x60			
70					4,8x70			

* Esclusivamente per alluminio e/o materiali leggeri (es. cartongesso, plastica ecc.)

Exclusively for aluminum and / or lightweight materials (eg. Plasterboard, plastics, etc.).

Le lunghezze standard sono quelle tra le due linee in grassetto.

The range of commercial lengths i between the bold stepped lines.

La dimensioni tra parentesi sono sconsigliate

The size in brackets should be avoided if possible

last edit 20/09/2019

DRAWING N. 1114

Продукт: [Винт Vira самопробивен за метал 4.2x32 мм, фрезенкова глава, PH, A2, DIN 7504P](#)

Категория: [Винтове за метал](#)

Бранд: [Vira](#)

Категория бранд: [Винт Vira](#)